

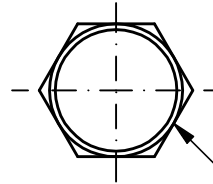

CHECK VALVE REVERSE GUIDED POPPET

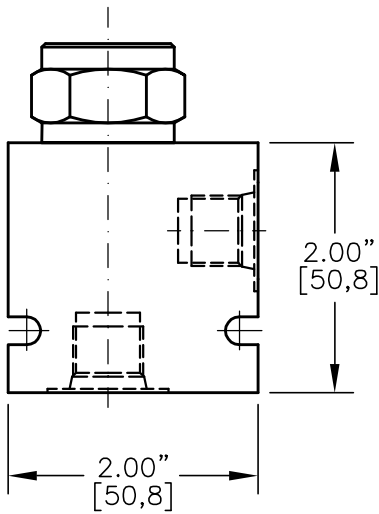

1.06" [27,0] HEX
TORQUE to 55/60 Ft-Lb.
[74/81 N-m]

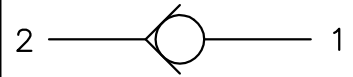
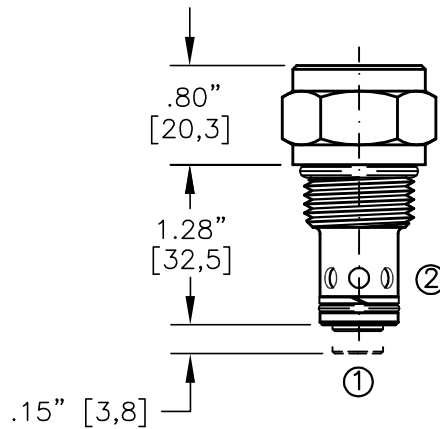

NOTE: CAVITY BOTTOM HOLE MUST ALLOW FOR POPPET EXTENSION (.570" DIA.)
FOR ALUMINUM OR STEEL VALVE HOUSING CONFIGURATIONS SEE PAGE 0-012.1

CVRP-10-X-X-XXX

- BASIC
- SIZE
10 = 7/8" - 14 UNF
- SEALS
N = BUNA "N"
V = VITON
- PORTS
0 = CARTRIDGE ONLY
02BX = G 1/2" BSPP
03BX = G 3/4" BSPP
06TX = SAE - #10
08TX = SAE - #12
- "A" - ALUM. HOUSING
"S" - STEEL HOUSING

- CRACK PRESSURE
- 005 = 5 PSI
- 015 = 15 PSI
- 030 = 30 PSI
- 060 = 60 PSI
- 120 = 120 PSI

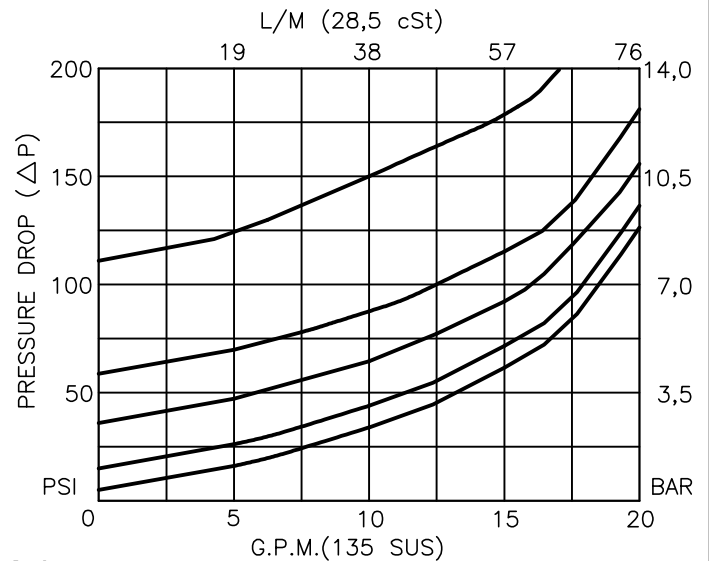



CHECK VALVE REVERSE GUIDED POPPET

DESCRIPTION

This unit is a SCREW IN, cartridge type, guided poppet, hydraulic check valve, used as a blocking or load holding device for high pressure applications.

OPERATIONS

This valve allows free flow from port 2 to port 1 and blocks flow from port 1 to port 2 or holding a load.

FEATURES AND BENEFITS

Wide selection of bias springs allows flexibility for back-pressure application.

All external carbon steel parts are plated for longer life against the elements. All cartridge valves are 100% functionally tested.

Industry common cavity.

SPECIFICATIONS

OPERATING PRESSURE: 5,000 PSI [350 Bar]

PROOF PRESSURE: 10,000 PSI [700 Bar]

FLOW: 18.0 GPM [68 l/m] nominal. See performance chart.

INTERNAL LEAKAGE: 5 drops per minute maximum @ 5,000 PSI [350 Bar]

VALVE HOUSINGS: 2500 PSI [175 Bar] = Aluminum - Anodized.

5000 PSI [350 Bar] = Steel - Unplated.

OPERATING TEMPERATURE: -40° to +250° F. [-40° to +120° C.]

OPERATING MEDIA: All general purpose hydraulic fluids such as MIL-H-5606, SAE-#10, SAE-#20, etc.

INSTALLATION: No restrictions.

SEAL KIT: SKN-1021 Buna "N"

SKV-1021 Viton

WEIGHT: .25 lb [.12 kg] cartridge only.

VALVE CAVITY: #C1020, See Page 0-012.0.